



**INSTRUCTIONS D'ASSEMBLAGE**  
**ASSEMBLY INSTRUCTIONS**

---

**M**ONARCH  
SPECIALTIES INC.

# I 3590

---

**TABLE D'APPOINT -**  
**23"H / MARBRE NOIR / METAL NOIR**

**ACCENT TABLE -**  
**23"H / BLACK MARBLE / BLACK METAL**



**POUR DE L'ASSISTANCE OU POUR COMMANDER  
DES PIÈCES CONTACTEZ NOTRE DÉPARTEMENT  
DE SERVICE À LA CLIENTÈLE.**

**FOR ASSISTANCE OR TO ORDER PARTS  
CONTACT OUR CUSTOMER SERVICE DEPARTMENT**

**WWW.MONARCHSERVICE.COM**

**LISTE DES PIÈCES**  
**PARTS LIST**

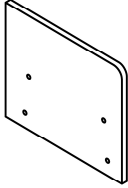
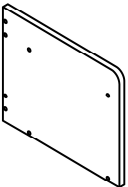
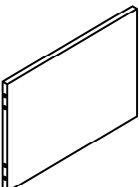
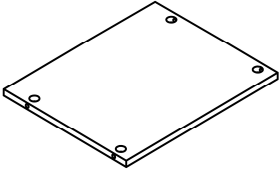
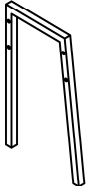
| PIÈCE / PART # | IMAGE   | DESCRIPTION  | QTY / QTÉ |
|----------------|---|--|-----------|
| 1              |    | <p>LEFT SIDE FACING PANEL<br/>PANNEAU DE GAUCHE</p>      | 1         |
| 2              |    | <p>RIGHT SIDE FACING PANEL<br/>PANNEAU DE CÔTÉ DROIT</p> | 1         |
| 3              |  | <p>BACK PANEL<br/>PANNEAU ARRIÈRE</p>                    | 1         |
| 4              |  | <p>SHELF<br/>ÉTAGÈRE</p>                                 | 2         |
| 5              |  | <p>FRONT FACING LEFT LEG<br/>PATTE AVANT GAUCHE</p>      | 1         |

**LISTE DES PIÈCES**  
**PARTS LIST**

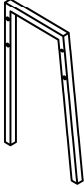
| PIÈCE / PART # | IMAGE   | DESCRIPTION                                  | QTY / QTÉ |
|----------------|---|--|-----------|
| 6              |  | FRONT FACING RIGHT LEG<br>PATTE AVANT DROITE | 1         |

**LISTE DES PIÈCES DE MONTAGE**  
**HARDWARE LIST**

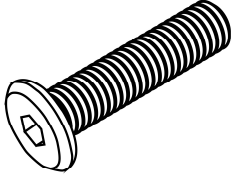
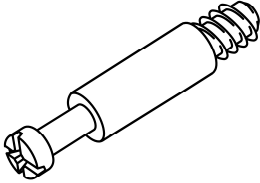
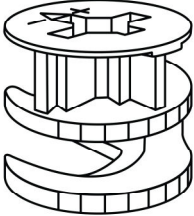
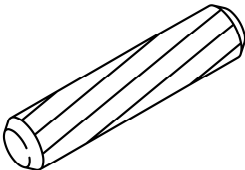
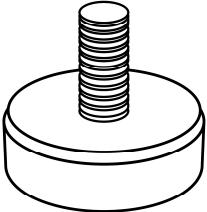
| PIÈCE / PART # | IMAGE   | DESCRIPTION  | QTY / QTÉ |
|----------------|---|--|-----------|
| A              |    | ASSEMBLING BOLT -<br>Ø 1/4" X 1 3/8"<br>BOULON D'ASSEMBLAGE -<br>Ø 1/4" X 1 3/8" | 8         |
| B              |    | CAM LOCK SCREW<br>VIS CAM LOCK   | 12        |
| C              |  | CAM LOCK CONNECTOR<br>ÉCROU CAM LOCK   | 12        |
| D              |  | WOOD DOWEL<br>GOUJON DE BOIS   | 12        |
| E              |  | ADJUSTABLE LEG -<br>Ø 1/4" X 5/8"<br>PATTE AJUSTABLE -<br>Ø 1/4" X 5/8"          | 4         |

**LISTE DES PIÈCES DE MONTAGE**  
**HARDWARE LIST**

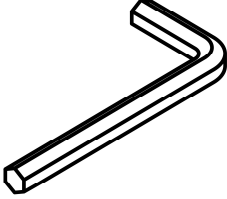
| PIÈCE / PART # | IMAGE   | DESCRIPTION               | QTY / QTÉ |
|----------------|---|---------------------------|-----------|
| F              |  | HEX KEY<br>CLÉ HEXAGONALE | 1         |

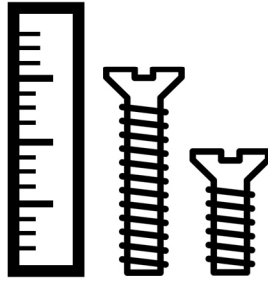

OUTIL DE VÉRIFICATION DE DIMENSIONS DES PIÈCES  
HARDWARE DIMENSIONS VERIFICATION TOOL

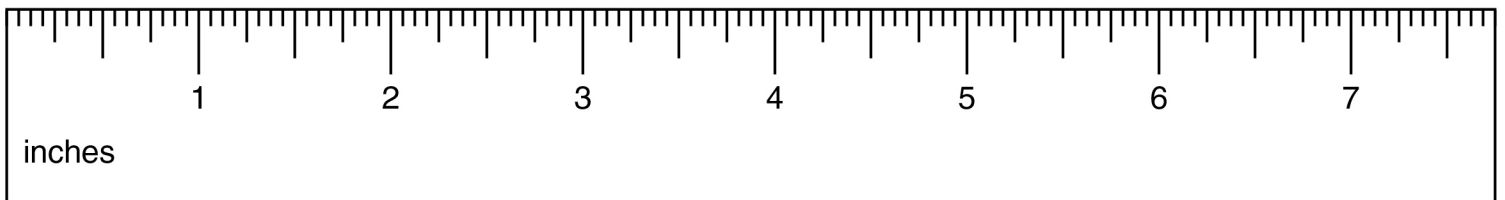

ÉTAPE / STEP 1

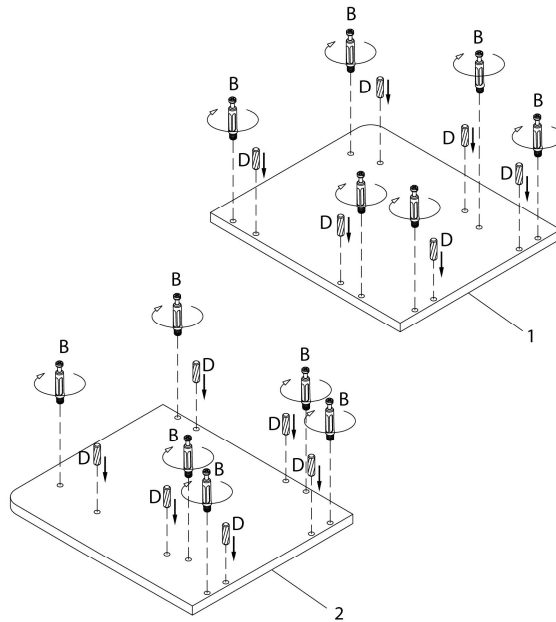

ÉTAPE / STEP 2

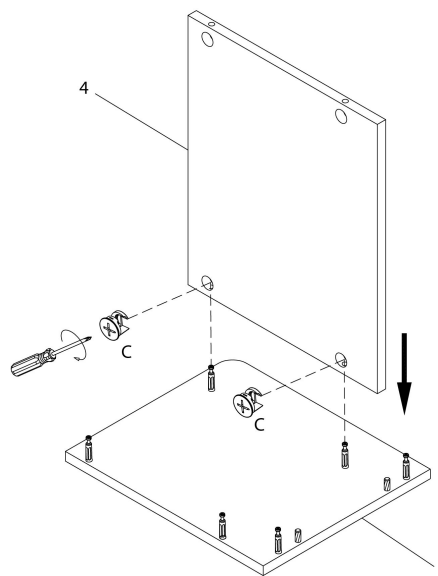

ÉTAPE / STEP 3

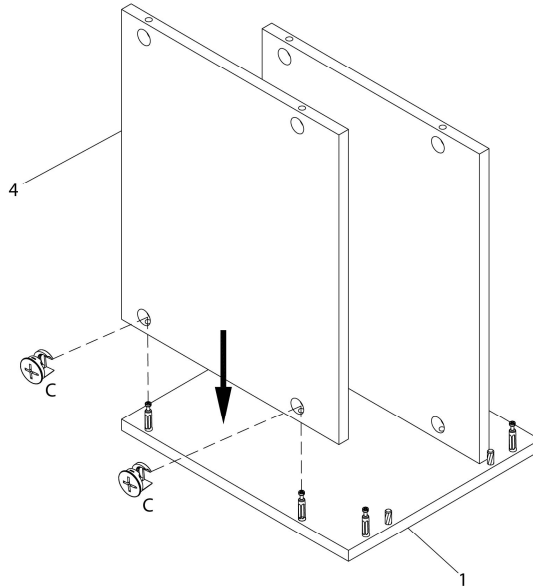

ÉTAPE / STEP 4

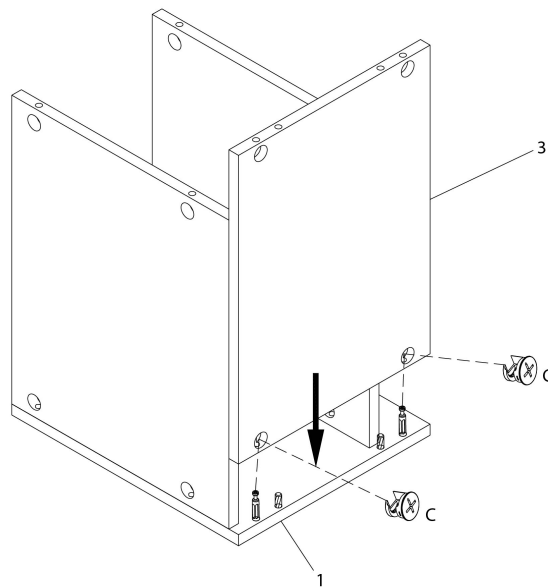



ÉTAPE / STEP 5

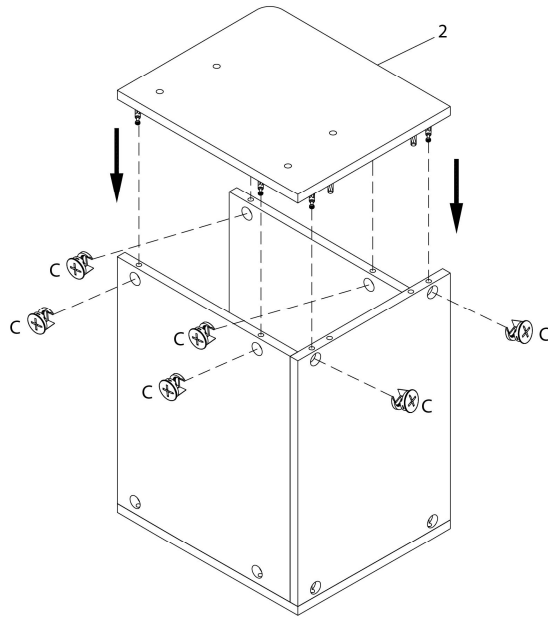

ÉTAPE / STEP 6

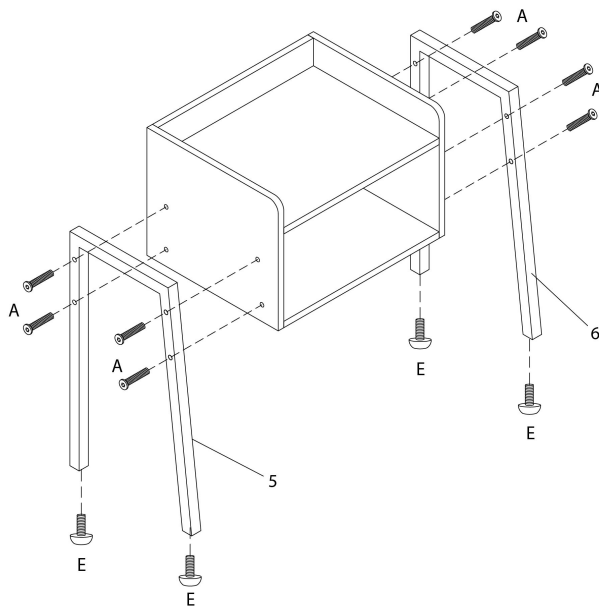

ÉTAPE / STEP 7

